

2017-2018

DISCOVERY



Resource Guide



THE WRIGHT STUFF: First in Flight

By Steve Perigard
Produced by Virginia Rep on Tour

Thursday, October 12, 2017
9:30 a.m. & 11:30 a.m.



VICTORIA THEATRE ASSOCIATION
VICTORIA - SCHUSTER - MAC/LOFT - ARTS ANNEX - ARTS GARAGE



Welcome to the 2017-2018 Discovery Series at Victoria Theatre Association. We are very excited to be your education partner in providing professional arts experiences to you and your students!

The story of the Wright Brothers and their amazing journey serves as an inspiration to students of all ages. What is special, though, is that if you live in the Dayton area, you have access to where history was made! Whether you dream of flying, or you want to uncover how a jet engine works, or you want to visit the spot where these two brothers had a simple bicycle shop, you can do it here in Dayton. I hope this show sparks your curiosity to find out even more about these aviation icons.

The information and activities in this resource guide have been carefully crafted to help you and your students explore the many ways a live theatre experience can open up learning opportunities. Grade level icons will help you determine which activities are good for students, too. And don't forget to take advantage of the local resources listed inside to extend the play-going experience and make even more curricular connections for you and your students. Thank you again and welcome!

Gary Minyard
Vice President -
Education & Engagement



Curriculum Connections



You will find these icons listed in the resource guide next to the activities that indicate curricular connections. Teachers and parents are encouraged to adapt all of the activities included in an appropriate way for your students' age and abilities. *THE WRIGHT STUFF: FIRST IN FLIGHT* fulfills the following Ohio and National Education Standards and Benchmarks for Grades 2 - 8:

Ohio's New Learning Standards for Science:

- Grade 2** - Earth & Space Science (the Atmosphere), Physical Science (Changes in Motion)
- Grade 3 & 4** - Physical Science (Matter and Forms of Energy)
- Grade 5** - Physical Science (Light, Sound, and Motion)
- Grade 6 & 7** - Physical Science (Matter and Motion)
- Grade 8** - Physical Science (Forces and Motion)

Ohio's New Learning Standards for Math:

- Measurement & Data (Grades 2-5)
- Operations and Algebraic Thinking (Grades 4-5)
- Geometry, Statistics & Probability (Grades 6-8)

Ohio's New Learning Standards for Social Studies:

- Historical Thinking and Skills (Grades 2-8), Heritage (Grades 2-8)
- People Working Together (Grade 2)
- Communities: Past and Present, Near, and Far (Grade 3)
- Ohio in the United States (Grade 4)

National Core Arts Theatre Standards:

- Grade 2** - TH:RE7.1.2, TH:Cn10.1.2, TH:Cn11.1.2, TH:Cn11.2.2
- Grade 3** - TH:Re7.1.3, TH:Cn10.1.3, TH:Cn11.1.3, TH:Cn11.2.3
- Grade 4** - Th:Re7.1.4, Th:Cn10.1.4, Th:Cn11.1.4, Th:Cn11.2.4
- Grade 5** - Th:Re7.1.5, TH:Cn10.1.5, TH:Cn11.1.5, TH:CN11.2.5
- Grade 6** - TH:Re7.1.6, TH:Cn10.1.6, TH:Cn11.1.6, TH:Cn11.2.6
- Grade 7** - Th:Re7.1.7, TH:Cn10.1.7, TH:Cn11.1.7, TH:CN11.2.7
- Grade 8** - TH:Re7.1.8, TH:Cn10.1.8, TH:Cn11.1.8, TH:Cn11.2.8

This resource guide was created by Amy Handra. All activities are available for distribution and use in the classroom or at home.

Table of Contents

About the Play and Ohio Spotlight	Page 2
COMPREHENSION	
The History of Flight	Page 3
Charting Early Flight	Page 4-5
Charting Early Flight Student Worksheet.....	Page 6
CONNECTION	
How Does an Airplane Fly?	Page 7
Conduct a Flight Experiment Student Worksheet	Page 8
CREATIVITY	
Grade Specific Classroom Activities and Worksheets	Page 9-13
The Dayton Aviation Trail.....	Page 14
Victoria Fuse's Local Resources	Page 15
Additional Resources for Students and Adults	Page 16

About the Play



It all started with the gift of a toy helicopter. Orville and Wilbur Wright's fascination with flying began when they were young boys and their father brought home a toy helicopter. The two young boys experimented with the toy and dreamed of one day building a flying machine that would be big enough to carry them through the sky.

In *THE WRIGHT STUFF: FIRST IN FLIGHT*, Orville, Wilbur, and their sister Katherine share their life story. From growing up in Dayton, Ohio, to their days as young entrepreneurs, to fulfilling their dream and becoming the father's of flight, the Wright family works together to overcome personal tragedy, and to pursue a dream that many thought was unattainable.

About Orville and Wilbur Wright

Born four years apart, brothers Wilbur and Orville Wright grew up in Dayton, Ohio. They shared an intellectual curiosity and an aptitude for science, at a time when the possibility of human flight was beginning to look like a reality. Together, the Wright brothers developed the first successful airplane in Kitty Hawk, North Carolina— and together they became national heroes. Considered the fathers of modern aviation, they developed innovative technology and inspired imaginations around the world.



Ohio Spotlight



Dayton Inventors River Walk

Did you know that Dayton is the birthplace of thousands of inventions? Among them are the backpack parachute, the ice cream cone, the artificial heart, and the yo-yo! Dayton has had more inventions per capita than many other cities in the United States. This is due to the numerous corporations that have called Dayton home. At one time, Dayton Engineering Laboratories Company (DELCO), Frigidaire, Mead, National Cash Register (NCR), General Motors, and Reynolds & Reynolds could all be found in Dayton. These companies, along with Wright-Patterson Air Force Base, brought inventive minds to Dayton and provided their employees with the resources to dream big and make their ideas a reality. Today you can visit seven Invention Stations at Riverscape Metro Park's **Dayton Inventors River Walk** along the great Miami River, commemorating inventions dreamed up right here in the Miami Valley.



For more information, visit <http://www.metroparks.org/river-walk/>.

COMPREHENSION

From Kite to Wright: The History of Flight



kitehistory.com

350 B.C.E. - The first kite is invented by Archytus of Tarentum in ancient Greece.

215 B.C.E. - Archimedes discovered why things float. His discovery is known as the Archimedes principle. This discovery was essential about 2,000 years later as inventors began to make balloons.

1490 - Leonardo da Vinci made drawings of parachutes, helicopters, propellers, and a flying machine with wings. He was also very interested in studying the anatomy of birds.

1783 - On October 15, 1783, Francois Piltre de Rozier made the first recorded ascent in a hot air balloon in France.

1891 - Beginning in 1891, German scientist Otto Lilienthal made thousands of flights in gliders, proving that heavier-than-air flight was possible.

1893 - Wilbur and Orville established their mechanical skills to work designing and repairing bicycles.

1903 - On December 17, near Kill Devil Hill, North Carolina, Orville Wright made the first controlled, sustained flight in a heavier-than-air vehicle. This event marked the era of modern aviation.

1908 - The Wright Brothers signed a contract with the U.S. Government for the construction of the first military airplane. A year later they formed the Wright Company to manufacture airplanes of their own design.

1948 - A special ceremony on December 17 celebrated the installation of the Wright Flyer in the Smithsonian Institution. The text written to hang below the Wright Brother's first airplanes reads, "By original scientific research, the Wright Brothers discovered the principles of human flight. As inventors, builders, and flyers, they further developed the aeroplane [sic.], taught man to fly, and opened the era of aviation."

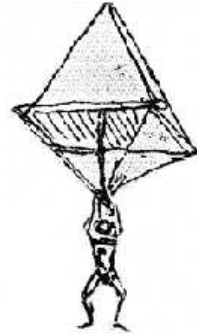

samilitary history.org

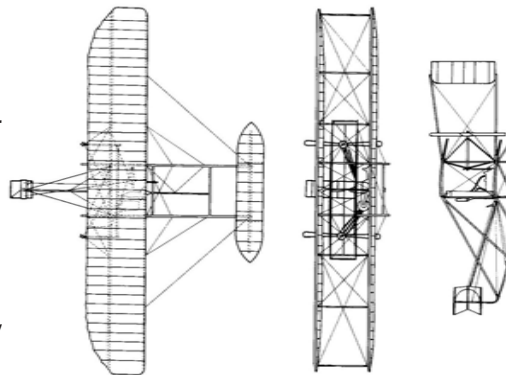

wright-brothers.org



Classroom Discussion

- Brainstorm a list of ways that Orville and Wilbur's experience in their bicycle shop may have helped them as they set out to invent a working airplane. Discuss your ideas.
- The invention of the airplane changed the world. Discuss ways in which this invention had a lasting impact on society.
- Has there been an invention or discovery since the Wright Brothers' time that had a similar impact? If so, what was the discovery or invention and how was the impact similar. If not, why has no other discovery or invention had the same impact as the airplane? Discuss your answers as a class.

COMPREHENSION

Charting Early Flight



The Wright Brothers had many attempts before they invented the first airplane in 1903, and they made many changes and additions to future models. Take a look at the following gliders and planes and notice the changes to the rudder and the addition of a propeller, engine, and skids!

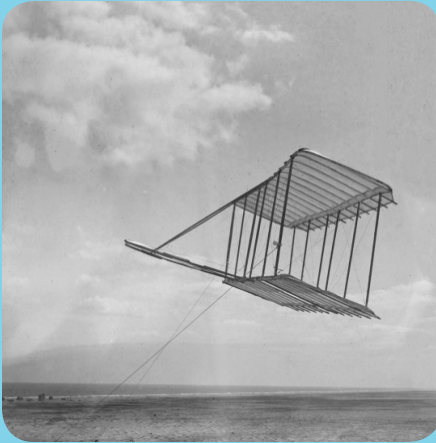

1900 Glider

Span: 17 ft.
Wing Area: 165 sq. ft.
Weight with Operator: 190 lbs.

Fast Facts

- Glider flown as a kite at Kitty Hawk, North Carolina
- First experiments sought to measure lift, drift, and center of pressure.
- Flights provided the Wright Brothers with first confirmation of flight theories.

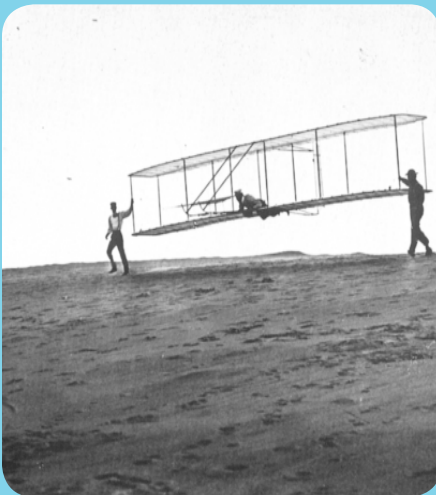

1902 Glider

Span: 32 ft.
Length: 16 ft.
Weight: 112 lbs.

Fast Facts

- The Wright Brothers made up to 1,000 glides at Kitty Hawk with this model.
- Wind tunnel tests were used to calculate the performance of their future flying machine.
- 1902 Glider was used again in 1903, just prior to testing the 1903 machine.



1903 Wright Flyer

Span: 40 ft.
Length: 21 ft.
Weight with Operator: 510 sq. ft.

Fast Facts

- 1903 Wright Flyer was essentially the 1902 Glider equipped with a motor and propellers.
- First succesful powered flight: December 7th; it lasted 12 seconds and they flew 120 ft.
- Now housed at the Smithsonian Museum in Washington, D.C.

COMPREHENSION

Charting Early Flight (continued)

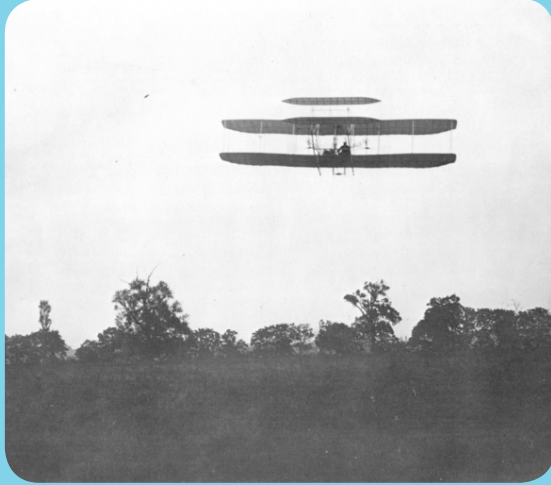

1905 Glider

Span: 40 ft. 6 in.
Length: 28 ft.
Wing Area: 503 sq. ft.

Fast Facts

- Modified so that pilot and passenger could sit upright.
- First model to have a bent-end propeller.
- Restored plane is now housed in Wright Hall at Carillon Historical Park in Dayton. Original parts include: engine, propellers, wing structure, and rudder struts.

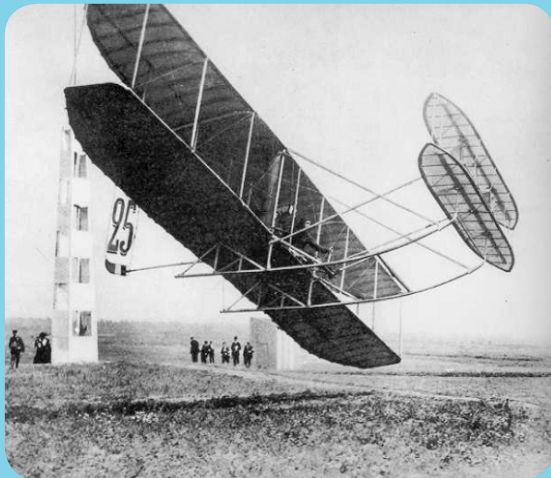

1907 - 1909 Glider

Span: 41 ft.
Length: 31 ft.
Wing Area: 510 sq. ft.

Fast Facts

- Conducted practice flights in France, Germany, and Italy.
- Machines from this period are sometimes referred to as the Wright Model A.
- Machine was purchased by the U.S. Army Signal Corps for \$30,000.

Images Courtesy of www.wright-brothers.org

Didn't the Wright Brothers fly in Dayton?

Many people think the Wright Brothers flew their gliders in Dayton before officially traveling to Kitty Hawk, NC. Here's the truth: the Wright Brothers did fly their first kites in Dayton but soon realized the weather conditions were not stable enough to continue their research. In 1900, they wrote the National Weather Bureau in Washington D.C. for a list of locations on the East Coast where the winds were constant. They suggested Kitty Hawk, and the rest is history!

CONNECTION

Charting Early Flight Student Worksheet



Name: _____ Date: _____

Utilizing the Charting Early Flight information on pages 3-5, can you answer with these questions?
Work alone or in groups, and see if you can answer all ten without looking!

1. Before the Wright Brothers invented the airplane, in what type of shop did they work?

2. At which famous museum can you see the 1903 Wright Flyer?

3. How wide was the wing span of the 1900 Glider?

4. What was the difference in width between the Wright Brothers' first glider and the 1909 Wright Model A?

5. What type of tests did the Wright Brothers run on the 1902 Glider?

6. How long was the first recorded flight of the 1903 Flyer?

7. Where does the 1905 Wright Flyer now reside?

8. In which European countries were the 1907-1909 Flyers tested?

9. How much did the U.S. Army Signal Corps pay for a brand new airplane in 1909?

How Does an Airplane Fly?

SCIENCE

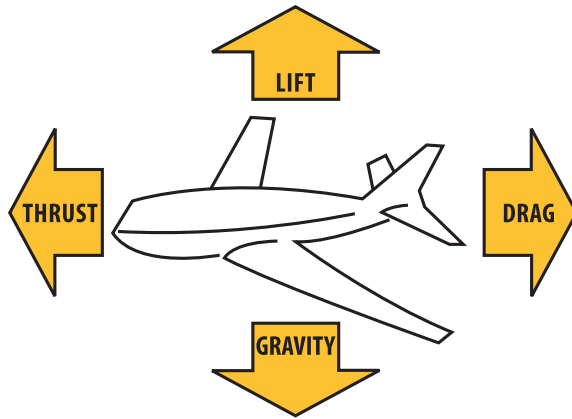

There are four forces that act on an airplane in flight: **thrust**, **drag**, **gravity**, and **lift**.

Thrust is the force that carries the airplane forward. It can be provided by the propeller or by jet propulsion.

Drag is the force that resists the forward motion of the plane. The amount of drag that a plane has depends on its shape and surface.

The **gravity** that pulls downward on a plane is the force between the Earth and the plane has depends on its shape and surface.

Lift is the force that overcomes gravity. It is caused by the motion of the air over and under the wings of an airplane. Lift can be produced in two ways—by the push of air against the slanted wing and by the **Bernoulli Effect**.

The **Bernoulli Effect** is named for Daniel Bernoulli, the Swiss Mathematician who first described the phenomenon. The Bernoulli Principle says that swiftly moving air creates an area of low pressure.

What Causes Lift?

SCIENCE

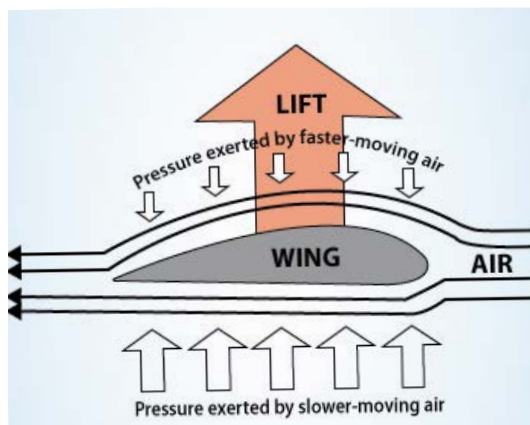

A plane's lifting power is due to the shape of its wings. The wings are more curved on top than they are underneath. This curve makes the top surface longer. Air flowing over the top of the wing must go faster to catch up with the air flowing underneath. This stretches the air on top, making it thinner, and its pressure drops. The air pressure above the wing is lower than the air pressure below the wing. The high-pressure air under the wing pushes upward and the wing is lifted.



CONNECTION

The Scientific Method

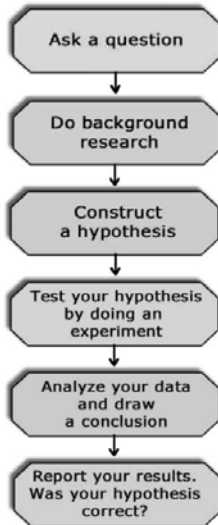

How did the Wright Brothers solve the problems that had stumped other would-be flyers for years? They succeeded because they were excellent scientists, whose work provided a great example of the scientific process.

Their great adventure began when they were just boys—curious about the toy flying machine called “the Alphonse Penaud helicoptère,” which was made of bamboo, paper, and cork. They examined the device closely and then made their own versions. They were already using two important parts of the scientific method— **observation** and **experimentation**.

You can follow the Wright example by making your own Penaud Helicopter and devising a series of experiments.

- Copy the pattern to the right onto stiff paper
- Cut along the solid lines
- Fold A forward
- Fold B backward
- Fold C forward
- Fold D backward
- Bend the stem at E

The finished helicopter should look like the picture to the left.

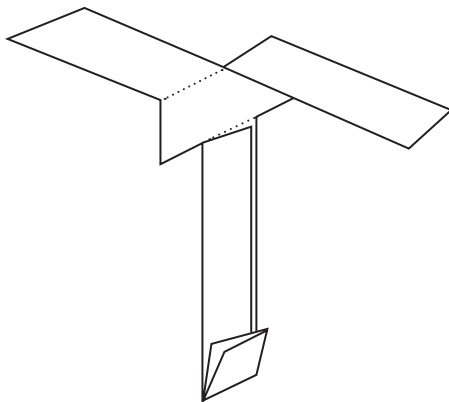

Courtesy of Theatre IV Study Guide

Conduct your own experiments! Hold stem upright and drop your helicopter from a high place. What happens when you reverse the direction of the flaps? What happens if you add a paperclip to the bottom of the helicopter to add weight? Add more paperclips and make a chart of your results.

A	B
C	D
E	

The Sled Kite Experiment Worksheet



Tape straw here

The Wright Brothers built kites, then gliders, and finally a powered airplane. You too can construct and fly a simple sled kite! Then, demonstrate how to make the kite fly at varying heights.

MATERIALS NEEDED:

- Sled Kite Template
- Two drinking straws
- Tape
- Scissors
- String
- Metric ruler
- Single-hole paper puncher
- One paper clip
- Markers, crayons, pencils
- Selection of paper (crepe, tissue, newspaper)

ACTIVITY INSTRUCTIONS

1. Make a copy of this Sled Kite Template on the largest paper available. Carefully cut out the kite.
2. Decorate the top of the sled kite using crayons, markers, or other media.
3. Trim the length of the two drinking straws so they will fit in the area marked for the straws. Tape them in place.
4. Place two or three pieces of tape in the marked areas covering the black circles.
5. Using a single-hole puncher, carefully punch two holes marked by the black circles.
6. Cut two pieces of kite string to connect through each hole.
7. Tie the opposite end of both strings to a paper clip.
8. Tie one end of piece of string to the other end of the paper clip. Your sled kite is ready to fly!
9. Outside in a clear area, hold the length of string and run with the kite to make it fly.
10. Run slow and run fast, and observe how the kite flies at different towing speeds.
11. Record your observations on the **Sled Kite Flying Student Worksheet** page.

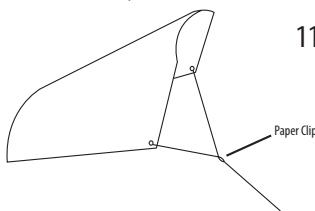
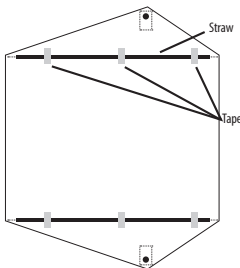

Tape straw here



Sled Kite Flying Student Worksheet



Name: _____ Date: _____

Describe today's weather, including wind speed and direction. _____

Predict what will happen with your Sled Kite under the following circumstances:

When you *walk* with your Sled Kite. _____

When you *run* with your Sled Kite. _____

Describe what actually happened when you walked with your kite. _____

Describe what actually happened when you ran with your kite. _____

Predict what will happen to your kite if you add a tail. _____

Describe how your kite flew with a tail. _____

Conduct experiments by flying your kite with a longer tail and a shorter tail.

Describe what happened when you flew your kite with a longer tail and a shorter tail. _____

First Flights Experiment Worksheet



Name: _____ Date: _____

Analyze and interpret data from the four flight trials of the Wright Brothers on December 17, 1903.

1. Use the data below and calculate the average speed of each flight trial.

Speed=Distance/Time					
Flight	Distance (Meters)		Time (Seconds)	=	Average Speed (m/sec)
1	37	÷	12	=	_____
2	53	÷	12	=	_____
3	61	÷	15	=	_____
4	260	÷	59	=	_____

2. Make a graph comparing the average speed of the four trials. What factor might have influenced the flight of the plane and caused such different speeds?

3. Analyze the graph "Speed vs. Time" below. Identify the events that occurred in the sections A, B, and C of the graph. Write a paragraph of what happened during the flight.

Extensions:

- The wind speed at Kitty Hawk was up to 12 meters/second and the speed of the machine of the ground against the wind was 3.05 meters per section. What would have been the speed of the machine in calm air? How far would it have traveled during the first flight with calm winds?
- The flight speeds were not as constant as the data might indicate. Instead there were control problems and erratic speeds. Investigate how the Wright Brothers solved these problems in later airplane designs.
- Use the graph "Speed vs. Time" as a model to create a graph that shows the changes in acceleration to the Wright Flyer during the flight.

The Graph to the right represents a mathematical method of how the Wright Brothers' first flight may have happened.

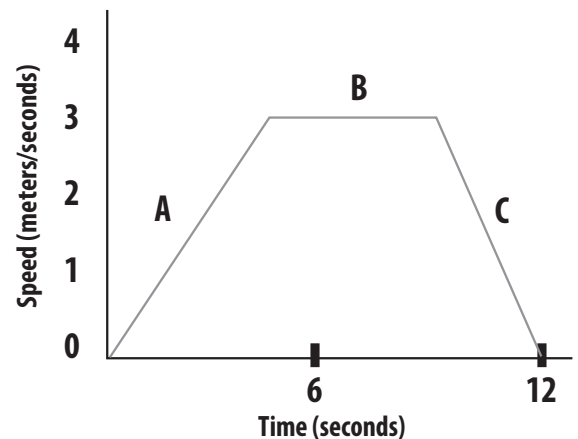

Finding Balance Experiment Worksheet



Name: _____ Date: _____

Orville and Wilbur's experiences in their bike shop primed them for the invention of the airplane. Why? They understood that both bikes and airplanes needed to be balanced, and the rider's (or pilot's) center of gravity must align with the machine's center of gravity.

This activity will demonstrate the relationship of an object's weight and the object's center of gravity. You will need:

- Darning Needle
- Knitting Needle
- Cork
- 2 cups
- 2 Candles
- 2 Plates to catch wax drippings

Push the knitting needle through the width of the work. Push the same knitting needle through a candle lengthwise, starting at the bottom of the candle. Using a different candles of equal size, repeat this procedure through the other end of the knitting needle. Then, push a darning needle lengthwise through the cork and place the needle on the tops of 2 cups. The two sides are balanced.

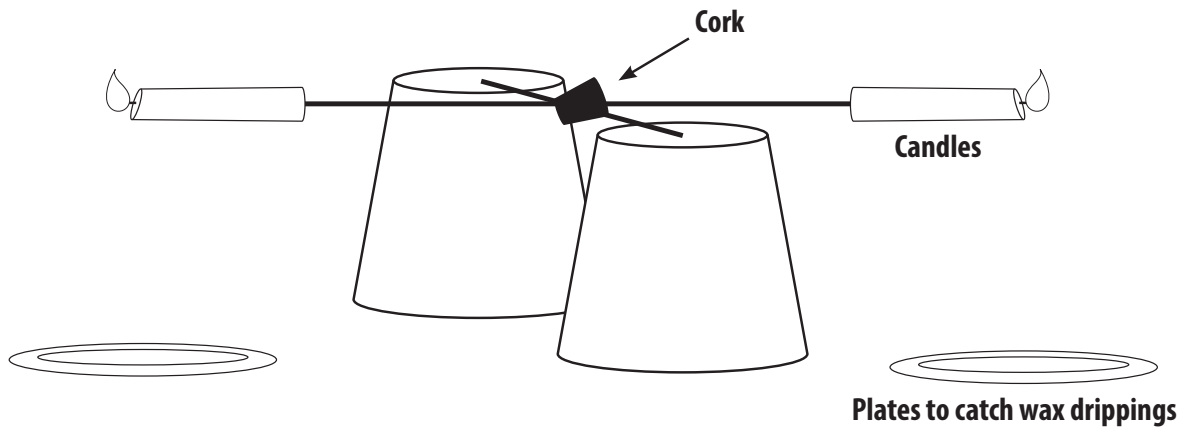

1. Predict what will happen if you light the ends of the seesaw candle.

2. Light the candles. Record your observations here:

3. How does this relate to how a person rides a bicycle?

4. How is the center of gravity important in building an airplane? **On a separate sheet of paper, draw an illustration depicting the center of gravity on an airplane.**

In Your Neighborhood

SOCIAL
STUDIES

THE DAYTON AVIATION TRAIL is a self-guided tour of selected, aviation-related sites that are open to the public. The Trail was established in 1981 by Aviation Trail, Inc., an all-volunteer organization whose mission is to preserve and promote Dayton's unique aviation heritage, starting with the invention of the airplane by Wilbur and Orville Wright.

In 1982, Aviation Trail, Inc. acquired two historic Wright Brothers' building that are still standing on their original sites in Dayton's West Side neighborhood: the Hoover Block and The Wright Cycle Company building. These eventually became the cornerstone of the Dayton Aviation Heritage Historical Park, a park of four sites managed by the National Park Service. In total, the Dayton Aviation Trail consists of 16 unique historical sites.

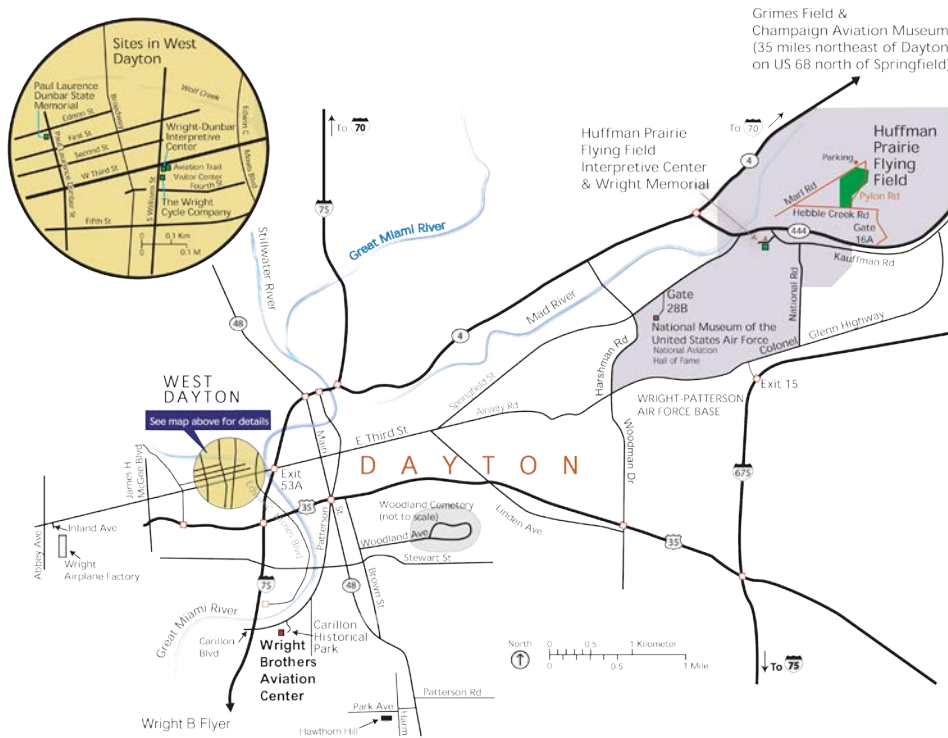

1. Wright-Dunbar Interpretive Center and Aviation Trail Visitor Center
2. Aviation Trail Parachute Museum
3. The Wright Cycle Company
4. Woodland Cemetery and Arboretum
5. Carillon Historical Park
6. Wright "B" Flyer
7. Historical WACO Field and WACO Airplane Museum
8. National Museum of the United States Air Force
9. National Aviation Hall of Fame
10. Wright State University
11. Wright Brothers Memorial
12. Huffman Praire Flying Field Interpretative Center
13. Huffman Praire Flying Field
14. Armstrong Air & Space Museum
16. Grimes Flying Lab

For more information about the Aviation Trail, visit <http://www.aviationtrailinc.org>.

RECOMMENDED RESOURCES



Victoria Fuse's Local Resources

The National Museum of the United States Air Force

110 Spaatz Street
Wright-Patterson AFB, OH 45433
(937) 255-3286

MUSEUM HOURS

Open daily 9 a.m. - 5 p.m.
Closed Thanksgiving, Christmas Day and New Year's Day

Free admission!

<http://www.nationalmuseum.af.mil/index.asp>

The National Museum of the United States Air Force is the oldest and largest military museum in the world - located at Wright-Patterson Air Force Base, near Dayton, Ohio. The National Museum of the United States Air Forces collects, researches, conserves, interprets and presents the Air Force's history, heritage and traditions.



Carrillon Historical Park

1000 Carillon Blvd
Dayton, OH 45409
(937) 293-2841

MUSEUM HOURS:

Monday - Saturday: 9:30 a.m. - 5:00 p.m.
Sundays: 12:00 p.m. - 5:00 p.m.

Carillon Historical Park's beautiful 65-acre campus features many one-of-a-kind aspects, and one of the main attractions is The John W. Berry Sr. Wright Brothers Aviation Center

which has more Wright artifacts on display than any place in the world, including the 1905 Wright Flyer III - the only airplane designated a National Historic Landmark, the world's first practical flying machine, and what the Wright brothers considered their most important aircraft. Adjacent to Wright Hall is Carillon Historical Park's Wright bicycle shop—a replica of Wilbur and Orville's fifth and final store at 1127 W. Third St. in West Dayton. In 1936, with Orville's endorsement, Henry Ford purchased the original building, and in 1938, it was moved from 1127 W. Third Street and dedicated at Greenfield Village at The Henry Ford Museum in Dearborn, Michigan. Carillon Park's cycle shop resembles how the Wright Brother's store would have appeared between mid-October-mid-December 1901.

For more information, visit <http://www.daytonhistory.org/>.



Did You Know?

If you visit at least 7 of the 16 Aviation Sites listed on page 14, you will receive a free "Willbear Wright" Aviation Teddy Bear courtesy of the National Park Service!

For more information, and how to download your Teddy Bear-Passport, visit <http://www.aviationtrailinc.org>.



RECOMMENDED RESOURCES

Resources for Students & Teachers



ADDITIONAL RESOURCES

PUBLICATIONS FOR STUDENTS:

Who Were the Wright Brothers?, Written by James Buckley, Jr. and Illustrated by Time Foley and Nancy Harrison. Grosset & Dunlap: 2014

The Wright Brothers: Inventors Whose Ideas Really Took Flight, Written by Mike Venezia. Childrens Press: 2010.

Flyer: A Tale of the Wright Dog, Written by Suzanne Tate and Illustrated by James Melvin. Nags Head Art, Inc.: 2003

Wilbur and Orville Wright: Young Fliers (Childhood of Famous Americans), Written by Augusta Stevenson, Aladdin Books: 1986.

The World Record Paper Airplane Book, Written by Ken Blackburn and Jeff Lammers. Workman Publishing Company: 2006.

The Wright Brothers for Kids: How They Invented the Airplane; 21 Activities Exploring the Science and History of Flight, Written by Mary Kay Carson. Chicago Review Press: 2003.

Can You Fly High, Wright Brothers?, Written by Melvin and Gilda Berger. Scholastic Nonfiction 2007.

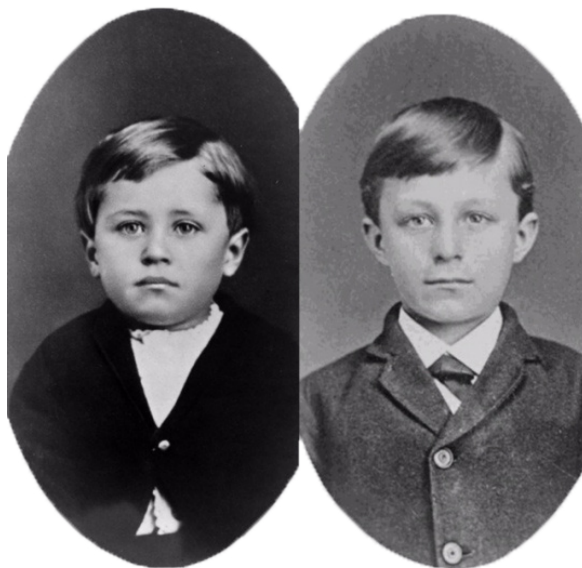

PUBLICATIONS FOR TEACHERS AND PARENTS:

Grand Eccentrics: Turning the Century— Dayton and the Inventing of America, Written by Mark Bernstein. Orange Frazer Press: 1996.

How Ohio Helped Invent the World: From the Airplane to the Yo-Yo, Written by Curt Dalton. CreateSpace Independent Publishing Platform: 2013.

The Wright Brothers, Written by David McCullough. Simon & Schuster: 2016.

WEBSITES:

www.nps.gov/daav/index.htm: The National Park Service has dedicated many sites in Dayton to be National Historic Landmarks. You can visit the Wright memorial, the Wright Cycle Company Building, Huffman Prairie Flying Field, and Hawthorne Hill.

wrightbrothers.info/index.php: This website is controlled by the Wright Family Fund and contains a gallery of photos, quotes, and biographies featuring Orville and Wilbur Wright.

education.nasa.gov: NASA's Education Home Page serves as the education portal for information regarding education programs and services offered by NASA for the American education community. This high-level directory of information provides specific details and points of contact for all of NASA's education efforts, Field Center offices, and point of present within each State.

Brought to you by



VICTORIA THEATRE ASSOCIATION
VICTORIA - SCHUSTER - MAC/LOFT - ARTS ANNEX - ARTS GARAGE
138 North Main Street
Dayton, OH 45402



The Education & Engagement programs of Victoria Theatre Association are made possible through the support and commitment of the following sponsors and donors whose generosity have opened the door of live theatre to the students of the Miami Valley:

PROGRAM SPONSORS

- Steve and Kate Hone
- The Frank M. Tait Foundation
- The Berry Family Foundation
- Rod & Regina Crane Charitable Fund
- Greenpoint Metals
- The Kuntz Foundation
- Mathile Family Foundation
- Ray Wylam

SUPPORT FOR FUELING EDUCATION IS GENEROUSLY PROVIDED BY
Greater Dayton Regional Transit Authority
Speedway LLC

VIRGINIA



Virginia Repertory is a nonprofit, professional theatre company and the result of the 2012 merger of Barksdale Theatre IV. With a budget of \$5 million, four distinct venues, an educational touring arm, and an annual audience over 550,000 Virginia Rep is the largest professional theatre and one of the largest performing arts organization in Central Virginia.

Mission Statement: Virginia Repertory Theatre creates professional production of the great comedies, dramas, and musicals - past, present and future. We seek to be a regional theatre of national standing. We embrace the art form in its entirety, presenting plays of all genres and national origins, serving and audience of all ages and backgrounds. Keeping with the legacies of Barksdale and Theatre IV, the hallmark of our nonprofit company is community engagement. To that end, we seek national caliber excellence in the arts, education, children's health, and community leadership.

For more information, please visit:
<https://va-rep.org/tour/>.

DON'T FORGET

All schools that receive scholarships for a show and/or transportation are asked and encouraged to create thank-you letters or cards for our sponsors. Please address your students' thank-you notes to:

DISCOVERY Sponsors
c/o Victoria Theatre Association
138 North Main Street
Dayton, OH 45402

